

salva

Panadería, Pastelería y Pizza
Bakery, Pastry and Pizza



Vanguardia con sabor a tradición desde 1943
Cutting-edge with a taste of tradition since 1943



Modular

eléctrico / electric



El horno modular Salva es reconocido en los sectores de panadería, pastelería y pizzería por su calidad de cocción, flexibilidad y polivalencia.

Se adapta a las necesidades productivas del cliente, ya que al estar formados por módulos o cámaras independientes apilables, cada cliente puede montar el horno a su medida. Además el hecho de tener módulos independientes hace que sean muy polivalentes, ya que permiten cocer diferentes tipos de producto en cada módulo.

La característica de estos hornos que los hace únicos reside en su sistema de distribución de calor. Un conjunto de ladrillos refractarios cerámicos atravesados por resistencias eléctricas, situados en techo y suelo, garantizan un reparto de calor uniformen toda la cámara, dotando a panes, pasteles y pizzas de un sabor, textura y aspecto únicos.

Salva modular ovens are renowned in the bakery, cakemaking and pizzeria sectors thanks to their quality of cooking, flexibility and range of options.

They adapt to the production requirements of each customer, since the independent, stackable chambers or modules allow the oven to be assembled as desired. Moreover, these independent modules give the ovens a high range of options, as different types of products can be cooked in each module.

The characteristic which makes these ovens unique is their heat distribution system. A series of refractory ceramic bricks crossed by electrical resistances situated in the upper and lower sections ensure the uniform distribution of heat throughout the chamber, hence giving bread, cakes and pizzas a unique taste, texture and appearance.

Modular

eléctrico / electric

Paneles de mandos / *Control panel*



E-ADVANCE

- TOUCH CONTROL.
- Fácil de programar y usar. / *Easy to program and use*
- Control de temperatura de 3 zonas. / *3 zone temperature control*
- Tiro motorizado. / *Motorized shot*
- 100 programas 10 fases en cada uno. / *100 programs 10 phases in each.*
- Parametro ECO: Autoapagado. / *ECO Parameter: Auto Off.*
- Parámetro ECU: Mantenimiento temperatura eficiente. / *ECU parameter: Efficient temperature maintenance*
- Carga de programas por Firmware. / *Program loading by firmware*

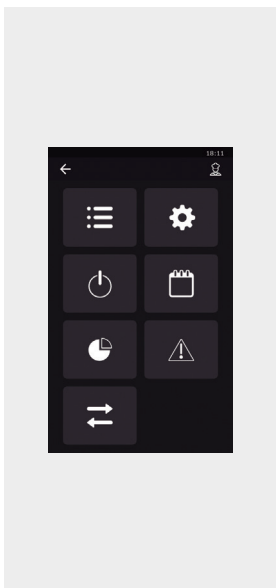

SMART TOUCH CONTROL STC

- Pantalla Gráfica de 7". / *Graphic display of 7"*
- Librería de Pictogramas incorporada. / *Built-in Pictogram Library.*
- Conexión SALVA LINK. / *SALVA LINK connection*
- Fácil de programar y usar. / *Easy to program and use*
- Control de temperatura de 3 zonas. / *3 zone temperature control.*
- Tiro motorizado. / *Motorized shot.*
- 150 programas 10 fases en cada uno. / *150 programs 10 phases in each*
- Menú gestión energética. / *Energy Management Menu*
- Calendario arranque temporizado. / *Timed Start Calendar.*
- Parametro ECO: Autoapagado. / *ECO Parameter: Auto Off.*
- Parámetro ECU: Mantenimiento temperatura eficiente. / *ECU parameter: Efficient temperature maintenance*
- Carga de programas por Firmware. / *Program loading by firmware*

Modular EM

eléctrico / electric

Características técnicas / Technical characteristics



TIPO / TYPE	Kw	Kcal/h	Fases Phases	V	A	Hz	Volumen Volume dm ³
MODULO EM-20 DECK EM-20	4,9	4.300	3N~	230/400	13,6 / 7,4	50 / 60	112
MODULO EM-20+V DECK EM-20+V	6,3	4.300	3N~	230/400	13,6 / 7,4	50 / 60	112
ESTUFA EM+H PROOFER EM+H	1,1	900	1N~	230	5	50 / 60	1.680

Dimensiones / Dimensions

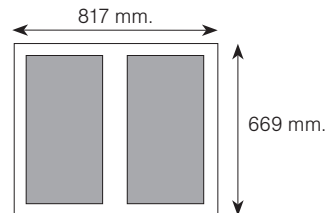
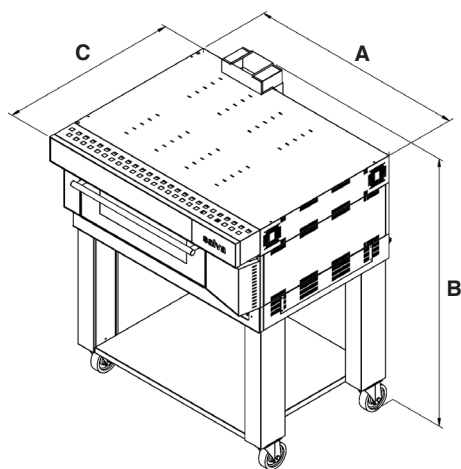

60 x 40
0,55 m²

Módulo Pastelero
Downward & outward opening module

EM	A mm	B mm	C mm	Peso / Weight Kg	Capacidad / Nº Trays
MODULO EM-20 DECK EM-20	1.317	315	1.073	141/155	2 (60 X 40)
MODULO EM-20 CON VAPOR DECK EM-20 + V	1.317	315	1.073 (*)	187	2 (60 X 40)
ESTUFA EM+H PROOFER EM+H	1.317	704	924	108	2 (60 X 40) X 5 Alturas / Levels
BASE EM BASE EM	1.317	150	924	50	-
ENCIMERA EM TOP EM	1.317	165	1.088	33	-

(*) El fondo se debe aumentar en 23 mm. debido a los tubos de desagüe.

(*) The depth should be increase in 23 millimetres for the pipes of outlet

Modular EM

eléctrico / electric

Accesorios / Accessories

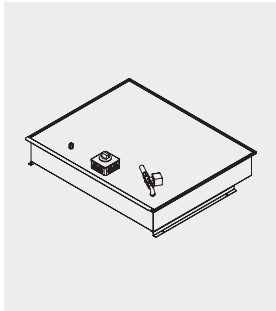

CONDENSADOR DE VAHOS / AUTOMATIC CONDENSER	
Código / Code	Descripción / Description
1124405100	CONDENSADOR VAHOS CV-E/13 (*) AUTOMATIC CONDENSER CV-E/13 (*)
1144405100	CONDENSADOR VAHOS CV-NXD/13 (**) AUTOMATIC CONDENSER CV-NXD/13 (**)

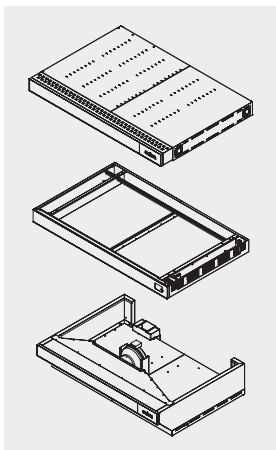

BASE/ENCIMERA / BASE/TOP	
Código / Code	Descripción / Description
1138136900	BASE/ENCIMERA EM/13 BASE/TOP EM/13
1138146900	BASE/ENCIMERA EM+V/13 BASE/TOP EM+V/13
1138136912	BASE/ENCIMERA EM/13 CON EXTRACTOR BASE/TOP EM/13 EXTRACTOR
1138136920	BASE/ENCIMERA EM/13 C/CVA BASE/TOP EM/13 C/CVA

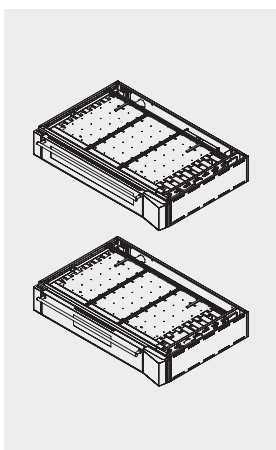

MODULO / DECK	
Código / Code	Descripción / Description
1138131900	MODULO EM-20/13 ADVANCE Puerta Pastelera DECK EM-20/13 ADVANCE Patisserie Door
1128631900	MODULO EM-20/21 STC Puerta Pastelera DECK EM-20/21 STC Patisserie Door
1138141900	MODULO EM-20/13 VAPOR ADVANCE Puerta Pastelera DECK EM-20/13 +V ADVANCE Patisserie Door
1128641900	MODULO EM-20/21 VAPOR STC Puerta Pastelera DECK EM-20/21 +V STC Patisserie Door

El horno incluye: Manopla Cogedor E
The oven includes: Heat resistant glove. Tray removing hook E

(*) Puede trabajar hasta 6 bandejas BH - 60x40 total
(**) Puede trabajar más de 8 bandejas BH - 60x40 total
(* It can work til 6 BH-60x40 trays total
(** It can work more than 8 BH-60x40 trays total

Modular EM

eléctrico / electric

Accesorios / Accessories

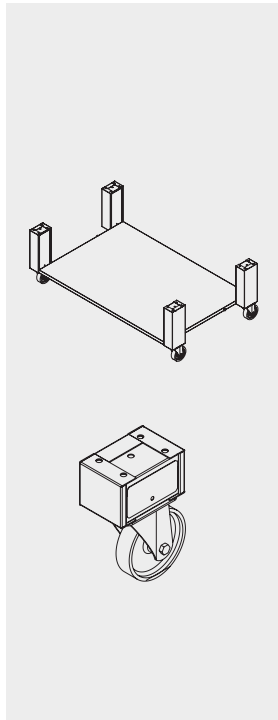

SOPORTE / TRAY SUPPORT	
Código / Code	Descripción / Description
1114493001	SOPORTE EM-350/13 (Altura Patas 350 mm+ Ruedas 200 mm) TRAY SUPPORT EM-350/13 (Height of legs 350 mm+ Castors 200 mm) Hasta 3 módulos / Up to 3 decks
1114493000	SOPORTE EM-435/13 (Altura Patas 435 mm+ Ruedas 200 mm) TRAY SUPPORT EM-435/13 (Height of legs 435 mm + Castors 200 mm) Hasta 3 módulos / Up to 3 decks
1114494000	SOPORTE EM-530/13 (Altura Patas 530 mm+ Ruedas 200 mm) TRAY SUPPORT EM-530/13 (Height of legs 530 mm + Castors 200 mm) Hasta 2 módulos / Up to 2 decks
1114495000	SOPORTE EM-630/13 (Altura Patas 630 mm+ Ruedas 200 mm) TRAY SUPPORT EM-630/13 (Height of legs 630 mm + Castors 200mm) Hasta 2 módulos / Up to 2 decks
1114496000	SOPORTE EM-730/13 (Altura Patas 730 mm+ Ruedas 200 mm) TRAY SUPPORT EM-730/13 (Height of legs 730 mm + Castors 200mm) Hasta 2 módulos / Up to 2 decks
1124491000	SOPORTE MODULAR 100 (Patas 100 mm+ Ruedas 200 mm) TRAY SUPPORT 100 (Legs 100 mm + Castors 200mm) Hasta 4 módulos / Up to 4 decks
1124492000	SOPORTE MODULAR 200 (Patas 200 mm+ Ruedas 200 mm) TRAY SUPPORT 200 (Legs 200 mm + Castors 200mm) Hasta 4 módulos / Up to 4 decks

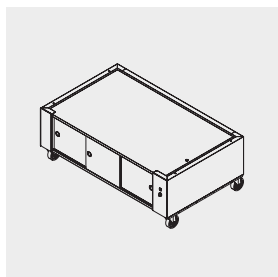

ESTUFA / PROOFER	
Código / Code	Descripción / Description
1138137900	ESTUFA EM/13 C/RUEDAS PROOFER EM/13 WITH CASTORS

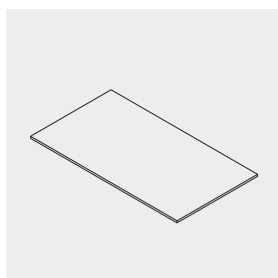

SOLERAS / COMPOSITE STONE SOLE	
Código / Code	Descripción / Description
1138133015	SOLERA CEMENTADA EM/13 JUEGO COMPOSITE STONE SOLE EM/13

El horno incluye: Manopla Cogedor E

The oven includes: Heat resistant glove. Tray removing hook E

(*) Puede trabajar hasta 6 bandejas BH - 60x40 total

(**) Puede trabajar más de 8 bandejas BH - 60x40 total

(*) It can work til 6 BH-60x40 trays total

(**) It can work more than 8 BH-60x40 trays total

Modular EMT

eléctrico / electric

Características técnicas / Technical characteristics



TIPO / TYPE	Kw	Kcal/h	Fases Phases	V	A	Hz	Volumen Volume dm ³
MODULO EMT-20 DECK EMT-20	6,1	4.300	3N~	230/400	13,6 / 7,4	50 / 60	112

Dimensiones / Dimensions

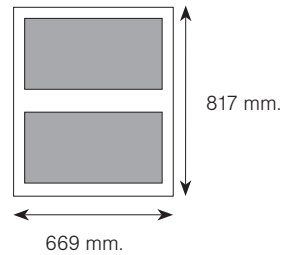
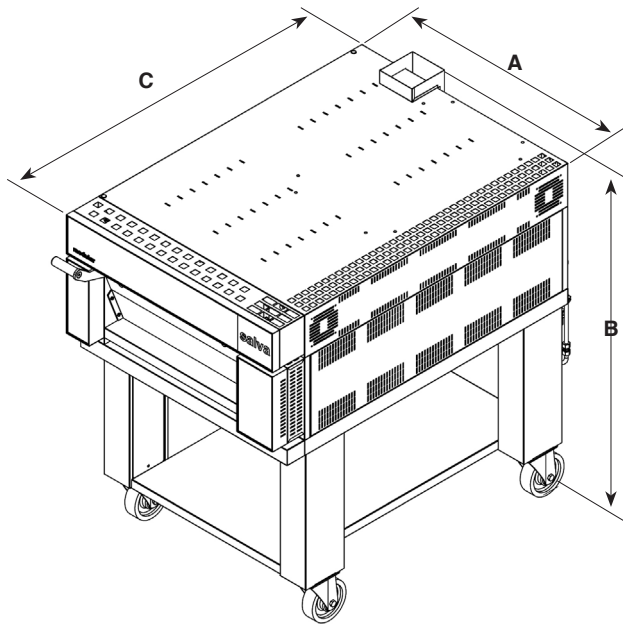

EM	A mm	B mm	C mm	Peso / Weight Kg	Capacidad / N° Trays
MODULO EMT-20 DECK EMT-20	915	315	1.398,5	-	2 (60 X 40)
BASE / ENCIMERA EMT BASE / TOP EMT	915	165	1.311,5	-	-

Modular EMT

eléctrico / *electric*

Accesorios / *Accessories*

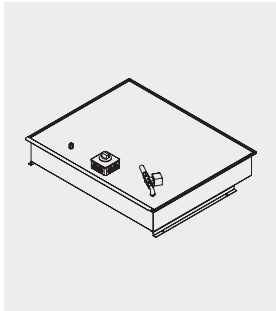

CONDENSADOR AUTOMÁTICO / <i>AUTOMATIC CONDENSER</i>		
Código / <i>Code</i>	Descripción / <i>Description</i>	
1138345100	CONDENSADOR VAHOS CV-EMT/16 <i>AUTOMATIC CONDENSER CV-EMT/16</i>	

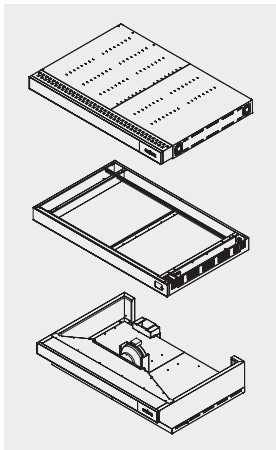

BASE/ENCIMERA / <i>BASE/TOP</i>		
Código / <i>Code</i>	Descripción / <i>Description</i>	
1138346900	BASE/ENCIMERA EMT+V/16 <i>BASE/TOP EMT+V/16</i>	
1138346920	BASE/ENCIMERA EMT/16 C/CVA <i>BASE/TOP EMT/16 C/CVA</i>	
1138346912	BASE/ENCIMERA EMT/16 C/EXTOR <i>BASE/TOP EMT/16 C/EXTOR</i>	

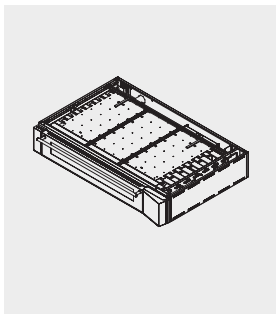

MODULO / <i>DECK</i>		
Código / <i>Code</i>	Descripción / <i>Description</i>	
1128341900	MODULO EMT-20/21 VAPOR STC. <i>DECK EMT-20/21 +V STC.</i>	

Modular EMT

eléctrico / *electric*

Accesorios / *Accessories*

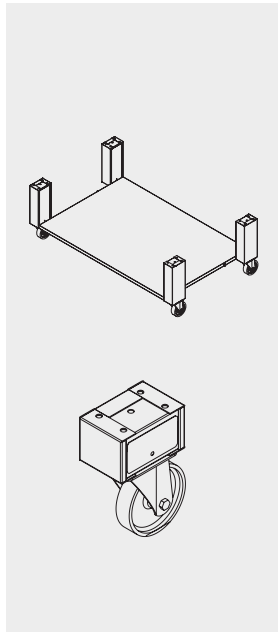

SOPORTE / TRAY SUPPORT	
Código / Code	Descripción / Description
1138348003	SOPORTE EMT 350 (Altura Patas 350 mm+ Ruedas 200 mm) <i>TRAY SUPPORT EMT 350/16 (Height of legs 350 mm+ Castors 200 mm)</i> Hasta 3 módulos / <i>Up to 3 decks</i>
1138348004	SOPORTE EMT 435 (Altura Patas 435 mm+ Ruedas 200 mm) <i>TRAY SUPPORT EMT 435/16 (Height of legs 435 mm+ Castors 200 mm)</i> Hasta 3 módulos / <i>Up to 3 decks</i>
1138348005	SOPORTE EMT 530 (Altura Patas 530 mm+ Ruedas 200 mm) <i>TRAY SUPPORT EMT 530/16 (Height of legs 530 mm+ Castors 200 mm)</i> Hasta 2 módulos / <i>Up to 2 decks</i>
1138348002	SOPORTE EMT 200 (Altura Patas 200 mm+ Ruedas 200 mm) <i>TRAY SUPPORT EMT 200 (Height of legs 200 mm+ Castors 200 mm)</i>

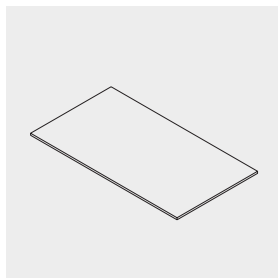

SOLERAS / COMPOSITE STONE SOLE	
Código / Code	Descripción / Description
1138343033	SOLERA CEMENTADA EMT/16 JUEGO <i>COMPOSITE STONE SOLE EMT/16</i>

Modular E

eléctrico / electric

Características técnicas / Technical characteristics



TIPO / TYPE	Kw	Kcal/h	Fases Phases	V	A	Hz	Volumen / Volume dm ³
MODULO E-20 DECK E-20	7,8	6.800	3N~	230/400	21,6 / 11,7	50/60	166
MODULO E-20+V DECK E-20+V	9,2	6.800	3N~	230/400	21,6 / 11,7	50/60	166
MODULO E-30 DECK E-30	9,8	8.500	3N~	230/400	27,0 / 14,7	50/60	249
MODULO E-30+V DECK E-30+V	11,20	8.500	3N~	230/400	27,0 / 14,7	50/60	249
ESTUFA E+H PROOFER E+H	2,2	1800	1N~	230	10	50/60	2.520

Dimensiones / Dimensions

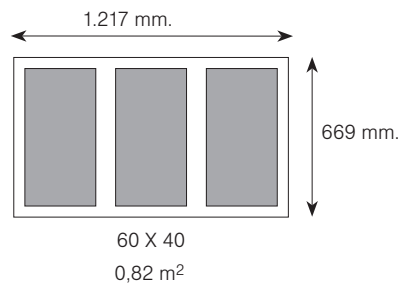
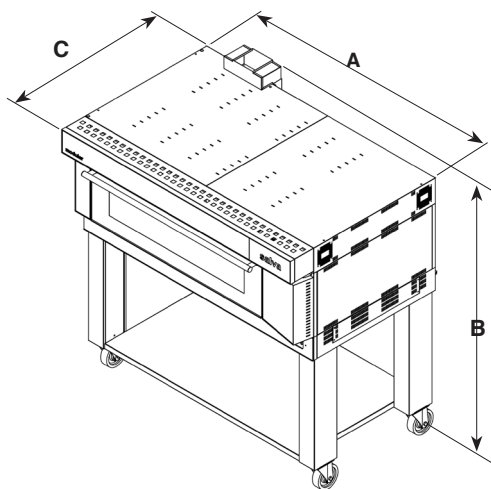

Módulo Pastelero
Downward & outward opening deck

E	A mm	B mm	C mm	Peso / Weight Kg	Capacidad / N° Trays
MODULO E-20 DECK E-20	1.717	315	1.073	168	3 (60 X 40)
MODULO E-20 CON VAPOR DECK E-20+V	1.717	315	1.073 (*)	236	3 (60 X 40)
MODULO E-30 DECK E-30	1.717	415	1.073	208	3 (60 X 40)
MODULO E-30 CON VAPOR DECK E-30+V	1.717	415	1.073 (*)	256	3 (60 X 40)
ESTUFA E+H PROOFER E+H	1.717	704	924	127	3 (60 X 40) X 5 Alturas / Levels
BASE E BASE E	1.717	150	924	65	-
ENCIMERA E TOP E	1.717	165	1.088	45	-

(*) El fondo se debe aumentar en 23 mm. debido a los tubos de desagüe.

(*) The depth should be increase in 23 millimetres for the pipes of outlet

Modular E

eléctrico / *electric*

Accesorios / *Accessories*

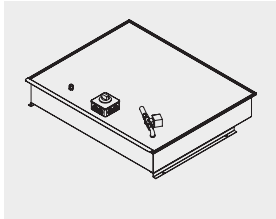

CONDENSADOR DE VAHOS / <i>AUTOMATIC CONDENSER</i>	
Código / <i>Code</i>	Descripción / <i>Description</i>
1124405100	CONDENSADOR VAHOS CV-E/13 (*) <i>AUTOMATIC CONDENSER CV-E/13 (*)</i>
1144405100	CONDENSADOR VAHOS CV-NXD/13 (**) <i>AUTOMATIC CONDENSER CV-NXD/13 (**)</i>

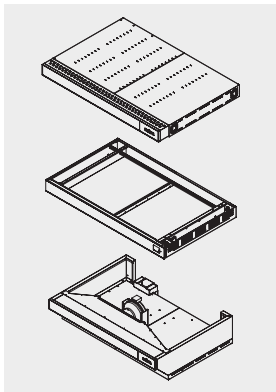

BASE/ENCIMERA / <i>BASE/TOP</i>	
Código / <i>Code</i>	Descripción / <i>Description</i>
1138016900	BASE/ENCIMERA E/13 <i>BASE/TOP E/13</i>
1138026900	BASE/ENCIMERA E+V/13 <i>BASE/TOP E+V/13</i>
1138016911	BASE/ENCIMERA E+V/13 CON EXTRACTOR <i>BASE/TOP E+V/13 EXTRACTOR</i>
1138016920	BASE/ENCIMERA E/13 C/CVA <i>BASE/TOP E/13 C/CVA</i>

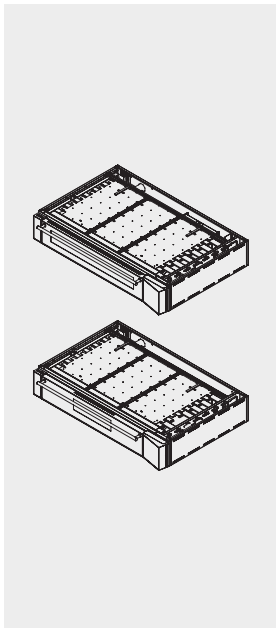

MODULO / <i>DECK</i>	
Código / <i>Code</i>	Descripción / <i>Description</i>
1138011900	MODULO E-20/13 ADVANCE Puerta Pastelera <i>DECK E-20/13 ADVANCE Patisserie Door</i>
1128511900	MODULO E-20/21 STC Puerta Pastelera <i>DECK E-20/21 STC Patisserie Door</i>
1138021900	MODULO E-20/13 VAPOR ADVANCE Puerta Pastelera <i>DECK E-20/13 +V ADVANCE Patisserie Door</i>
1128521900	MODULO E-20/21 VAPOR STC Puerta Pastelera <i>DECK E-20/21 +V STC Patisserie Door</i>
1138041900	MODULO E-30/13 ADVANCE Puerta Pastelera <i>DECK E-30/13 ADVANCE Patisserie Door</i>
1128541900	MODULO E-30/21 STC Puerta Pastelera <i>DECK E-30/21 STC Patisserie Door</i>
1138051900	MODULO E-30/13 VAPOR ADVANCE Puerta Pastelera <i>DECK E-30/13 +V ADVANCE Patisserie Door</i>
1128551900	MODULO E-30/21 VAPOR STC Puerta Pastelera <i>DECK E-30/21 +V STC Patisserie Door</i>

El horno incluye: Manopla Cogedor E
The oven includes: Heat resistant glove. Tray removing hook E

(*) Puede trabajar hasta 6 bandejas BH - 60x40 total
 (**) Puede trabajar más de 8 bandejas BH - 60x40 total
 (*) *It can work til 6 BH-60x40 trays total*
 (**) *It can work more than 8 BH-60x40 trays total*

Modular E

eléctrico / electric

Accesorios / Accessories

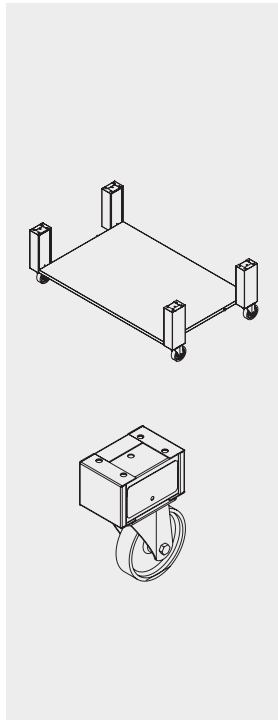

SOPORTE / TRAY SUPPORT	
Código / Code	Descripción / Description
1124493001	SOPORTE E-350/13 (Altura Patas 350 mm+ Ruedas 200 mm) TRAY SUPPORT E-350/13 (Height of legs 350 mm+ Castors 200 mm)
1124493000	SOPORTE E-435/13 (Altura Patas 435 mm+ Ruedas 200 mm) TRAY SUPPORT E-435/13 (Height of legs 435 mm + Castors 200 mm) Hasta 3 módulos / Up to 3 decks
1124494000	SOPORTE E-530/13 (Altura Patas 530 mm+ Ruedas 200 mm) TRAY SUPPORT E-530/13 (Height of legs 530 mm + Castors 200 mm) Hasta 2 módulos / Up to 2 decks
1124495000	SOPORTE E-630/13 (Altura Patas 630 mm+ Ruedas 200 mm) TRAY SUPPORT E-630/13 (Height of legs 630 mm + Castors 200 mm) Hasta 2 módulos / Up to 2 decks
1124496000	SOPORTE E-730/13 (Altura Patas 730 mm+ Ruedas 200 mm) TRAY SUPPORT E-730/13 (Height of legs 730 mm + Castors 200 mm) Hasta 2 módulos / Up to 2 decks
1124491000	SOPORTE MODULAR 100 (Patas 100 mm+ Ruedas 200 mm) TRAY SUPPORT MODULAR 100 (Legs 100 mm + Castors 200 mm) Hasta 4 módulos / Up to 4 decks
1124492000	SOPORTE MODULAR 200 (Patas 200 mm+ Ruedas 200 mm) TRAY SUPPORT MODULAR 200 (Legs 200 mm + Castors 200 mm) Hasta 4 módulos / Up to 4 decks

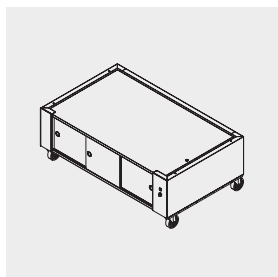

ESTUFA / PROOFER	
Código / Code	Descripción / Description
1138017900	ESTUFA E/13 C/RUEDAS PROOFER E+H/13 WITH CASTORS

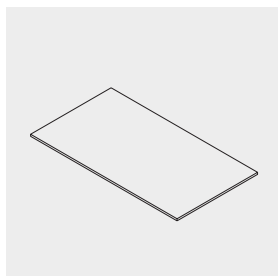

SOLERAS / COMPOSITE STONE SOLE	
Código / Code	Descripción / Description
1138013037	SOLERA CEMENTADA E/13 (JUEGO) COMPOSITE STONE SOLE E/13

El horno incluye: Manopla Cogedor E

The oven includes: Heat resistant glove. Tray removing hook E

(*) Puede trabajar hasta 6 bandejas BH - 60x40 total

(**) Puede trabajar más de 8 bandejas BH - 60x40 total

(*) It can work til 6 BH-60x40 trays total

(**) It can work more than 8 BH-60x40 trays total

PANADERÍA Y PASTELERÍA BAKERY AND PASTRY

Modular EMD

eléctrico / electric

Características técnicas / Technical characteristics



TIPO / TYPE	Kw	Kcal/h	Fases Phases	V	A	Hz	Volumen / Volume dm ³
MODULO EMD-20 DECK EMD-20	9,1	7.900	3N~	230/400	25,1 / 13,7	50 / 60	214
MODULO EMD-20+V DECK EMD-20+V	11,6	7.900	3N~	230/400	25,1 / 13,7	50 / 60	214
ESTUFA EMD+H PROOFER EMD+H	2,2	1800	1N~	230	10	50 / 60	3.360

Dimensiones / Dimensions

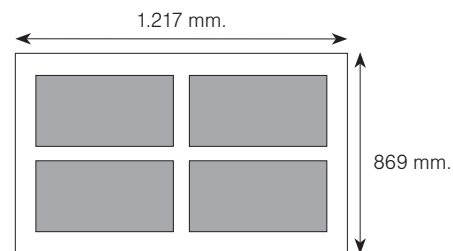
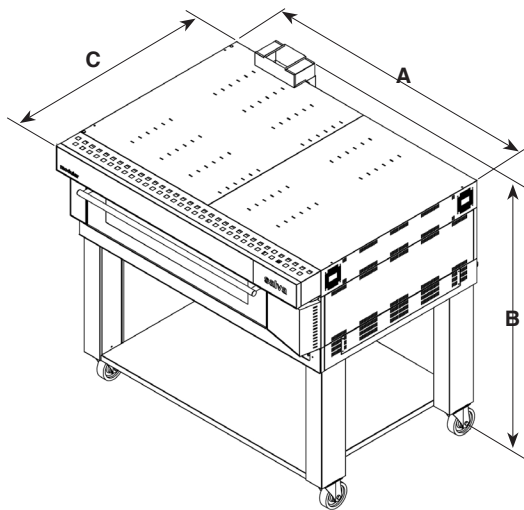

60 X 40

1,06 m²

Módulo Pastelero

Downward & outward opening deck

EMD	A mm	B mm	C mm	Peso / Weight Kg	Capacidad / N° Trays
MODULO EMD-20 DECK EMD-20	1.717	315	1.273	199	4 (60 X 40)
MODULO EMD-20 CON VAPOR DECK EMD-20 + V	1.717	315	1.273	270	4 (60 X 40)
ESTUFA EMD+H PROOFER EMD+H	1.717	704	1.124	139	3 (60 X 40) X 5 Alturas / Levels
BASE EMD BASE EMD	1.717	150	1.124	73	-
ENCIMERA EMD TOP EMD	1.717	165	1.288	50	-

(*) El fondo se debe aumentar en 23 mm. debido a los tubos de desagüe.

(*) The depth should be increase in 23 millimetres for the pipes of outlet

Modular EMD

eléctrico / *electric*

Accesorios / *Accessories*

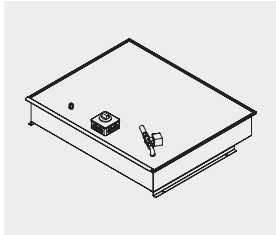

CONDENSADOR DE VAHOS / *AUTOMATIC CONDENSER*

Código / Code	Descripción / Description
1124405100	CONDENSADOR VAHOS CV-E/13 (*) <i>AUTOMATIC CONDENSER CV-E/13 (*)</i>
1144405100	CONDENSADOR VAHOS CV-NXD/13 (**) <i>AUTOMATIC CONDENSER CV-NXD/13 (**)</i>

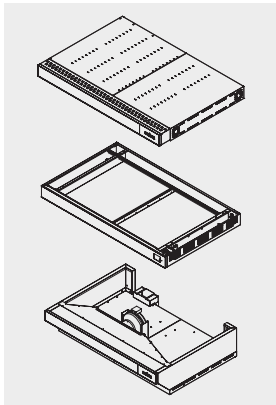

BASE/ENCIMERA / *BASE/TOP*

Código / Code	Descripción / Description
1138166900	BASE/ENCIMERA EMD/13 <i>BASE/TOP EMD/13</i>
1138176900	BASE/ENCIMERA EMD+V/13 <i>BASE/TOP EMD+V/13</i>
1138176911	BASE/ENCIMERA EMD+V/13 CON EXTRACTOR <i>BASE/TOP EMD+V/13 EXTRACTOR</i>
1138176920	BASE/ENCIMERA EMD/13 C/CVA <i>BASE/TOP EMD/13 C/CVA</i>

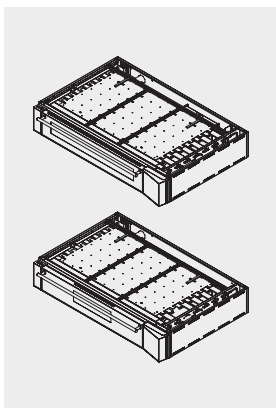

MODULO / *DECK*

Código / Code	Descripción / Description
1138161900	MODULO EMD-20/13 ADVANCE Puerta Pastelera <i>DECK EMD-20/13 ADVANCE Patisserie Door</i>
1128661900	MODULO EMD-20/21 STC Puerta Pastelera <i>DECK EMD-20/21 STC Patisserie Door</i>
1138171900	MODULO EMD-20/13 VAPOR ADVANCE Puerta Pastelera <i>DECK EMD-20/13 +V ADVANCE Patisserie Door</i>
1128671900	MODULO EMD-20/21 VAPOR STC Puerta Pastelera <i>DECK EMD-20/21 +V STC Patisserie Door</i>

El horno incluye: Manopla Cogedor E
The oven includes: Heat resistant glove. Tray removing hook E

(*) Puede trabajar hasta 6 bandejas BH - 60x40 total
(**) Puede trabajar más de 8 bandejas BH - 60x40 total
(*) *It can work til 6 BH-60x40 trays total*
(**) *It can work more than 8 BH-60x40 trays total*

Modular EMD

eléctrico / electric

Accesorios / Accessories

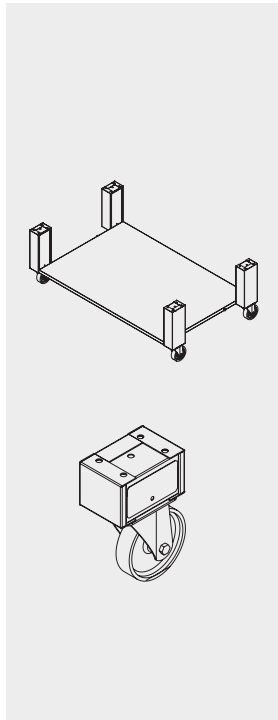

SOPORTE / TRAY SUPPORT	
Código / Code	Descripción / Description
1174493001	SOPORTE EMD-350/13 (Altura Patas 350 mm+ Ruedas 200 mm) TRAY SUPPORT EMD-350/13 (Height of legs 350 mm+ Castors 200 mm) Hasta 3 módulos / Up to 3 decks
1174493000	SOPORTE EMD-435/13 (Altura Patas 435 mm+ Ruedas 200 mm) TRAY SUPPORT EMD-435/13 (Height of legs 435 mm + Castors 200 mm) Hasta 3 módulos / Up to 3 decks
1174494000	SOPORTE EMD-530/13 (Altura Patas 530 mm+ Ruedas 200 mm) TRAY SUPPORT EMD-530/13 (Height of legs 530 mm + Castors 200 mm) Hasta 2 módulos / Up to 2 decks
1174495000	SOPORTE EMD-630/13 (Altura Patas 630 mm+ Ruedas 200 mm) TRAY EMD-630/13 (Height of legs 630 mm + Castors 200 mm) Hasta 2 módulos / Up to 2 decks
1174496000	SOPORTE EMD-730/13 (Altura Patas 730 mm+ Ruedas 200 mm) TRAY SUPPORT EMD-730/13 (Height of legs 730 mm + Castors 200 mm) Hasta 2 módulos / Up to 2 decks
1124491000	SOPORTE MODULAR 100 (Patas 100 mm+ Ruedas 200 mm) TRAY SUPPORT 100 (Legs 100 mm + Castors 200 mm) Hasta 4 módulos / Up to 4 decks
1124492000	SOPORTE MODULAR 200 (Patas 200 mm+ Ruedas 200 mm) TRAY SUPPORT 200 (Legs 200 mm+ Castors 200 mm) Hasta 4 módulos / Up to 4 decks

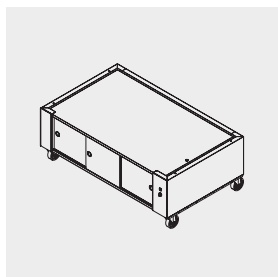

ESTUFA / PROOFER	
Código / Code	Descripción / Description
1138167900	ESTUFA EMD+H/13 C/RUEDAS PROOFER EMD+H/13 WITH CASTORS

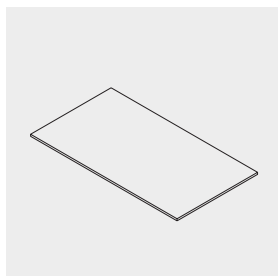

SOLERAS / COMPOSITE STONE SOLE	
Código / Code	Descripción / Description
1138163006	SOLERA CEMENTADA EMD/13 JUEGO COMPOSITE STONE SOLE EMD/13

El horno incluye: Manopla Cogedor E
The oven includes: Heat resistant glove. Tray removing hook E

- (*) Puede trabajar hasta 6 bandejas BH - 60x40 total
- (**) Puede trabajar más de 8 bandejas BH - 60x40 total
- (*) It can work til 6 BH-60x40 trays total
- (**) It can work more than 8 BH-60x40 trays total

Modular ED

eléctrico / electric

Características técnicas / Technical characteristics



TIPO / TYPE	Kw	Kcal/h	Fases Phases	V	A	Hz	Volumen / Volume dm ³
MODULO ED-20 DECK ED-20	13	11.300	3N~	400	19,3	50/60	312
MODULO ED-20+V DECK ED-20+V	15,5	11.300	3N~	400	22,9	50/60	312
MODULO EDP-20+V DECK EDP-20+V	15,5	11.300	3N~	400	22,9	50/60	312
MODULO ED-30 DECK ED-30	16,3	14.100	3N~	400	21,1	50/60	468
MODULO ED-30+V DECK ED-30+V	18,8	14.100	3N~	400	27,8	50/60	468

Dimensiones / Dimensions

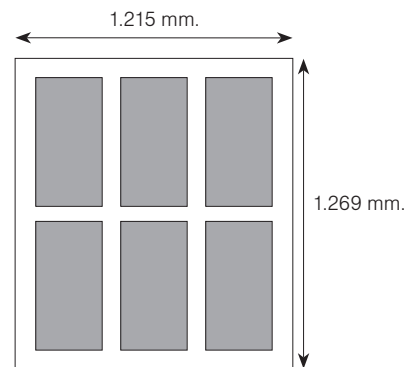
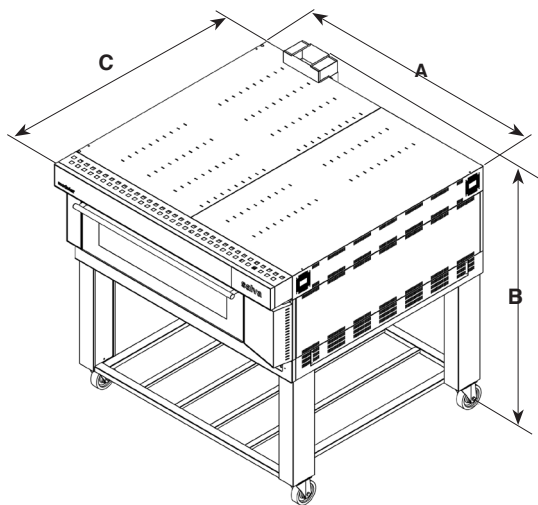

60 x 40
1,54 m²

Módulo Pastelero
Downward & outward opening deck

ED	A mm	B mm	C mm	Peso / Weight Kg	Capacidad / N° Trays
MODULO ED-20 DECK ED-20	1.717	315	1.673	260	6 (60 X 40)
MODULO ED-20 CON VAPOR / EDP-20 CON VAPOR DECK ED-20 +V / EDP-20 +V	1.717	315	1.673 (*)	340	6 (60 X 40)
MODULO ED-30 DECK ED-30	1.717	415	1.673	297	6 (60 X 40)
MODULO ED-30 CON VAPOR DECK ED-30 +V	1.717	415	1.673 (*)	375	6 (60 X 40)
BASE ED BASE ED	1.717	150	1.524	95	-
ENCIMERA ED TOP ED	1.717	165	1.688	65	-

(*) El fondo se debe aumentar en 23 mm. debido a los tubos de desagüe.

(*) The depth should be increase in 23 millimetres for the pipes of outlet

Modular ED

eléctrico / electric

Accesorios / Accessories

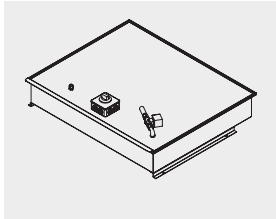

CONDENSADOR DE VAHOS / AUTOMATIC CONDENSER	
Código / Code	Descripción / Description
1124405100	CONDENSADOR VAHOS CV-E/13 (*) AUTOMATIC CONDENSER CV-E/13 (*)
1144405100	CONDENSADOR VAHOS CV-NXD/13 (**) AUTOMATIC CONDENSER CV-NXD/13 (**)

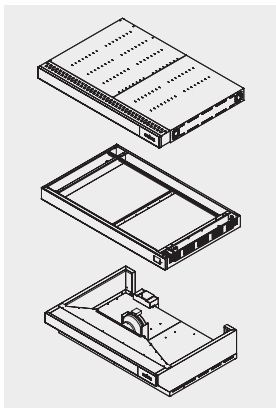

BASE/ENCIMERA / BASE/TOP	
Código / Code	Descripción / Description
1138076900	BASE/ENCIMERA ED/13 BASE/TOP ED/13
1138086900	BASE/ENCIMERA ED+V/13 BASE/TOP ED+V/13
1138076911	BASE/ENCIMERA ED+V/13 EXTRACTOR BASE/TOP ED+V/13 EXTRACTOR
1138076920	BASE/ENCIMERA ED/13 C/CVA BASE/TOP ED/13 C/CVA

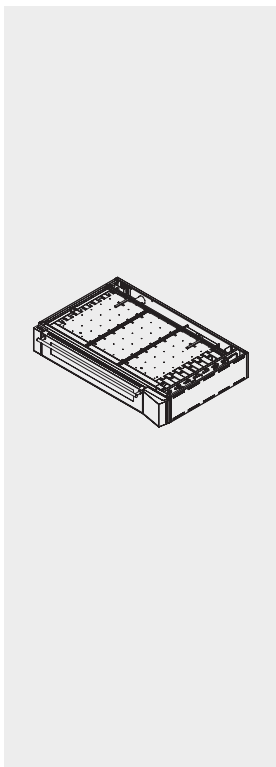

MODULO / DECK	
Código / Code	Descripción / Description
1138071900	MODULO ED-20/13 400V ADVANCE Puerta Pastelera DECK ED-20/13 400V ADVANCE Patisserie Door
1128571900	MODULO ED-20/21 400V STC Puerta Pastelera DECK ED-20/21 400V STC Patisserie Door
1138081900	MODULO ED-20/13 VAPOR 400V ADVANCE Puerta Pastelera DECK ED-20/13 +V 400V ADVANCE Patisserie Door
1128581900	MODULO ED-20/21 VAPOR 400V STC Puerta Pastelera DECK ED-20/21 +V 400V STC Patisserie Door
1138091900	MODULO EDP-20/13 VAPOR 400V ADVANCE Puerta Panadera DECK EDP-20/13 +V 400V ADVANCE Baker's Door
1128591900	MODULO EDP-20/21 VAPOR 400V STC Puerta Panadera DECK EDP-20/21 +V 400V STC Baker's Door
1138101900	MODULO ED-30/13 400V ADVANCE Puerta Pastelera DECK ED-30/13 400V ADVANCE Patisserie Door
1128601900	MODULO ED-30/21 400V STC Puerta Pastelera DECK ED-30/21 400V STC Patisserie Door
1138111900	MODULO ED-30/13 VAPOR 400V ADVANCE Puerta Pastelera DECK ED-30/13 +V 400V ADVANCE Patisserie Door
1128611900	MODULO ED-30/21 VAPOR 400V STC Puerta Pastelera DECK ED-30/21 +V 400V STC Patisserie Door

El horno incluye: Manopla Cogedor E

The oven includes: Heat resistant glove. Tray removing hook E

(*) Puede trabajar hasta 6 bandejas BH - 60x40 total

(**) Puede trabajar más de 8 bandejas BH - 60x40 total

(*) It can work til 6 BH-60x40 trays total

(**) It can work more than 8 BH-60x40 trays total

Modular ED

eléctrico / electric

Accesorios / Accessories

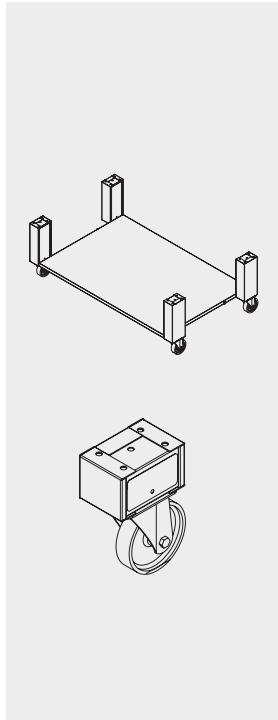

SOPORTE / TRAY SUPPORT	
Código / Code	Descripción / Description
1134493001	SOPORTE ED-350/13 (Altura Patas 350 mm+ Ruedas 200 mm) TRAY SUPPORT ED-350/13 (Height of legs 350 mm+ Castors 200 mm) Hasta 3 módulos / Up to 3 decks
1134493000	SOPORTE ED-435/13 (Altura Patas 435 mm+ Ruedas 200 mm) TRAY SUPPORT ED-435/13 (Height of legs 435 mm + Castors 200 mm) Hasta 3 módulos / Up to 3 decks
1134494000	SOPORTE ED-530/13 (Altura Patas 530 mm+ Ruedas 200 mm) TRAY SUPPORT ED-530/13 (Height of legs 530 mm + Castors 200 mm) Hasta 2 módulos / Up to 2 decks
1134495000	SOPORTE ED-630/13 (Altura Patas 630 mm+ Ruedas 200 mm) TRAY SUPPORT ED-630/13 (Height of legs 630 mm + Castors 200 mm) Hasta 2 módulos / Up to 2 decks
1134496000	SOPORTE ED-730/13 (Altura Patas 730 mm+ Ruedas 200 mm) TRAY SUPPORT ED-730/13 (Height of legs 730 mm + Castors 200 mm) Hasta 2 módulos / Up to 2 decks
1124491000	SOPORTE MODULAR 100 (Patas 100 mm+ Ruedas 200 mm) TRAY SUPPORT 100 (Legs 100 mm + Castors 200 mm) Hasta 4 módulos / Up to 4 decks
1124492000	SOPORTE MODULAR 200 (Patas 200 mm+ Ruedas 200 mm) TRAY SUPPORT 200 (Legs 200 mm + Castors 200 mm) Hasta 4 módulos / Up to 4 decks

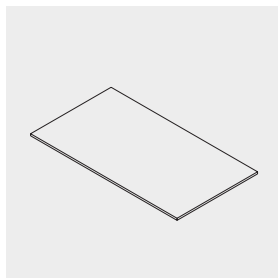

SOLERAS / COMPOSITE STONE SOLE	
Código / Code	Descripción / Description
1138073010	SOLERA CEMENTADA ED/13 JUEGO COMPOSITE STONE SOLE ED/13

El horno incluye: Manopla Cogedor E
The oven includes: Heat resistant glove. Tray removing hook E

(*) Puede trabajar hasta 6 bandejas BH - 60x40 total
(**) Puede trabajar más de 8 bandejas BH - 60x40 total
(* It can work til 6 BH-60x40 trays total
(** It can work more than 8 BH-60x40 trays total

Modular NXM

eléctrico / electric

Características técnicas / Technical characteristics



TIPO / TYPE	Kw	Kcal/h	Fases Phases	V	A	Hz	Volumen / Volume dm ³
MODULO NXM-20 DECK NXM-20	6,6	5.700	3N~	230/400	18,3 / 9,9	50/60	176
MODULO NXM-20 +V DECK NXM-20 +V	8	5.700	3N~	230/400	18,3 / 9,9	50/60	176
MODULO NXM-30 DECK NXM-30	8,2	7.100	3N~	230/400	22,8 / 12,4	50/60	176
MODULO NXM-30 +V DECK NXM-30 +V	9,6	7.100	3N~	230/400	22,8 / 12,4	50/60	176
MODULO NXMP-20 +V DECK NXMP-20 +V	8	5.700	3N~	230/400	18,3 / 9,9	50/60	158
ESTUFA NXM+H PROOFER NXM+H	1,1	900	1N~	230	5	50/60	2.359

Dimensiones / Dimensions

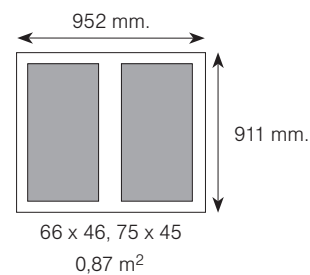
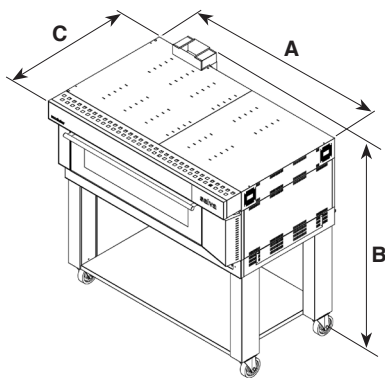

Módulo Pastelero
Downward & outward opening deck

NXM	A mm	B mm	C mm	Peso / Weight Kg	Capacidad / Nº Trays
MODULO NXM-20 DECK NXM-20	1.452	315	1.316	170	2 (76 X 46)
MODULO NXM-20 CON VAPOR DECK NXM-20 +V	1.452	315	1.316 (*)	220	2 (76 X 46)
MODULO NXM-30 DECK NXM-30	1.452	415	1.316	203	2 (76 X 46)
MODULO NXM-30 +V DECK NXM-30 +V	1.452	415	1.316	251	2 (76 X 46)
MODULO NXMP-20 +V DECK NXMP-20 +V	1.452	315	1.364	225	2 (76 X 46)
ESTUFA NXM+H PROOFER NXM+H	1.452	704	1.167	118	2 (76 X 46) X 5 Alturas / Levels
BASE NXM BASE NXM	1.452	150	1.167	60	-
ENCIMERA NXM TOP NXM	1.452	165	1.331	43	-

(*) El fondo se debe aumentar en 23 mm. debido a los tubos de desagüe.

(*) The depth should be increase in 23 millimetres for the pipes of outlet

Modular NXM

eléctrico / *electric*

Accesorios / *Accessories*

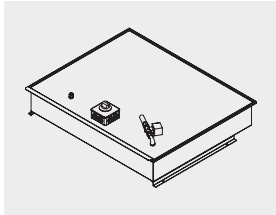

CONDENSADOR DE VAHOS / <i>AUTOMATIC CONDENSER</i>	
Código / <i>Code</i>	Descripción / <i>Description</i>
1124405100	CONDENSADOR VAHOS CV-E/13 (*) <i>AUTOMATIC CONDENSER CV-E/13 (*)</i>
1144405100	CONDENSADOR VAHOS CV-NXD/13 (**) <i>AUTOMATIC CONDENSER CV-NXD/13 (**)</i>

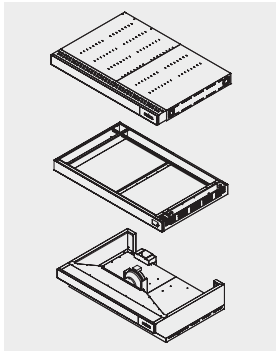

BASE/ENCIMERA / <i>BASE/TOP</i>	
Código / <i>Code</i>	Descripción / <i>Description</i>
1138226900	BASE/ENCIMERA NXM/13 <i>BASE/TOP NXM/13</i>
1138236900	BASE/ENCIMERA NXM+V/13 <i>BASE/TOP NXM+V/13</i>
1138226911	BASE/ENCIMERA NXM+V/13 CON EXTRACTOR <i>BASE/TOP NXM+V/13 EXTRACTOR</i>
1138226920	BASE/ENCIMERA NXM/13 C/CVA <i>BASE/TOP NXM/13 C/CVA</i>

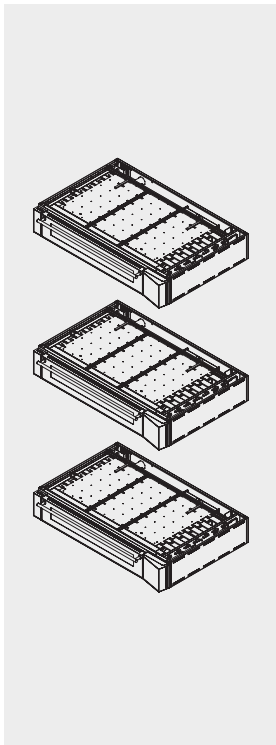

MODULO / <i>DECK</i>	
Código / <i>Code</i>	Descripción / <i>Description</i>
1138221900	MODULO NXM-20/13 ADVANCE Puerta Pastelera <i>DECK NXM-20/13 ADVANCE Patisserie Door</i>
1128721900	MODULO NXM-20/21 STC Puerta Pastelera <i>DECK NXM-20/21 STC Patisserie Door</i>
1138231900	MODULO NXM-20/13 VAPOR ADVANCE Puerta Pastelera <i>DECK NXM-20/13 +V ADVANCE Patisserie Door</i>
1128731900	MODULO NXM-20/21 VAPOR STC Puerta Pastelera <i>DECK NXM-20/21 +V STC Patisserie Door</i>
1138371900	MODULO NXMP-20/13 VAPOR ADVANCE Puerta Panadera <i>DECK NXMP-20/13 +V ADVANCE Baker's Door</i>
1128871900	MODULO NXM-20/21 VAPOR STC Puerta Panadera <i>DECK NXM-20/21 +V STC Baker's Door</i>
1138401900	MODULO NXM-30/13 ADVANCE Puerta Pastelera <i>DECK NXM-30/13 ADVANCE Patisserie Door</i>
1128901900	MODULO NXM-30/21 STC Puerta Pastelera <i>DECK NXM-30/21 STC Patisserie Door</i>
1138411900	MODULO NXM-30/13 VAPOR ADVANCE Puerta Pastelera <i>DECK NXM-30/13 +V ADVANCE Patisserie Door</i>
1128911900	MODULO NXM-30/21 VAPOR STC Puerta Pastelera <i>DECK NXM-30/21 +V STC Patisserie Door</i>

El horno incluye: Manopla Cogedor E

The oven includes: Heat resistant glove. Tray removing hook E

(*) Puede trabajar hasta 6 bandejas BH - 60x40 total

(**) Puede trabajar más de 8 bandejas BH - 60x40 total

(*) *It can work til 6 BH-60x40 trays total*

(**) *It can work more than 8 BH-60x40 trays total*

Modular NXM

eléctrico / *electric*

Accesorios / *Accessories*

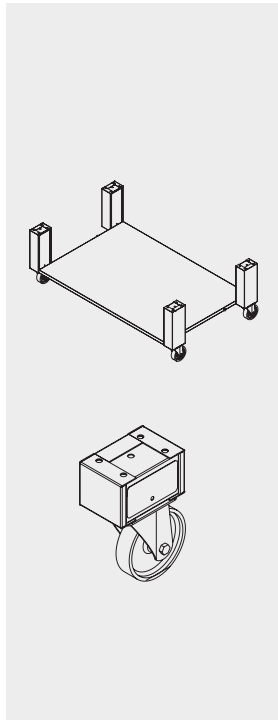

SOPORTE / <i>TRAY SUPPORT</i>	
Código / <i>Code</i>	Descripción / <i>Description</i>
1138228003	SOPORTE NXM-350/13 (Altura Patas 350 mm+ Ruedas 200 mm) <i>TRAY SUPPORT NXM-350/13 (Height of legs 350 mm+ Castors 200 mm)</i> Hasta 3 módulos / <i>Up to 3 decks</i>
1138228004	SOPORTE NXM-435/13 (Altura Patas 435 mm+ Ruedas 200 mm) <i>TRAY SUPPORT NXM-435/13 (Height of legs 435 mm + Castors 200 mm)</i> Hasta 3 módulos / <i>Up to 3 decks</i>
1138228005	SOPORTE NXM-530/13 (Altura Patas 530 mm+ Ruedas 200 mm) <i>TRAY SUPPORT NXM-530/13 (Height of legs 530 mm + Castors 200 mm)</i> Hasta 2 módulos / <i>Up to 2 decks</i>
1138228006	SOPORTE NXM-630/13 (Altura Patas 630 mm+ Ruedas 200 mm) <i>TRAY SUPPORT NXM-630/13 (Height of legs 630 mm + Castors 200 mm)</i> Hasta 2 módulos / <i>Up to 2 decks</i>
1138228007	SOPORTE NXM-730/13 (Altura Patas 730 mm+ Ruedas 200 mm) <i>TRAY SUPPORT NXM-730/13 (Height of legs 730 mm + Castors 200 mm)</i> Hasta 2 módulos / <i>Up to 2 decks</i>
1124491000	SOPORTE MODULAR 100 (Patas 100 mm+ Ruedas 200 mm) <i>TRAY SUPPORT 100 (Legs 100 mm + Castors 200 mm)</i> Hasta 4 módulos / <i>Up to 4 decks</i>
1124492000	SOPORTE MODULAR 200 (Patas 200 mm+ Ruedas 200 mm) <i>TRAY SUPPORT 200 (Legs 200 mm + Castors 200 mm)</i> Hasta 4 módulos / <i>Up to 4 decks</i>

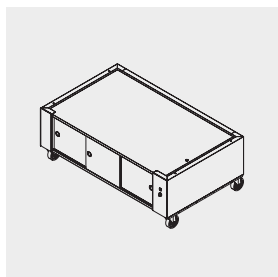

ESTUFA / <i>PROOFER</i>	
Código / <i>Code</i>	Descripción / <i>Description</i>
1138227900	ESTUFA NXM/13 C/RUEDAS <i>PROOFER NXM/13 WITH CASTORS</i>

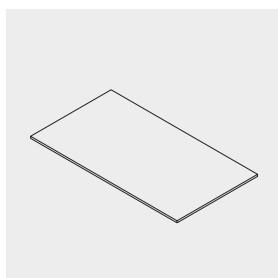

SOLERAS / <i>COMPOSITE STONE SOLE</i>	
Código / <i>Code</i>	Descripción / <i>Description</i>
1138223001	SOLERA CEMENTADA NXM/13 JUEGO <i>COMPOSITE STONE SOLE NXM/13</i>

El horno incluye: Manopla Cogedor E

The oven includes: Heat resistant glove. Tray removing hook E

(*) Puede trabajar hasta 6 bandejas BH - 60x40 total

(**) Puede trabajar más de 8 bandejas BH - 60x40 total

(*) *It can work til 6 BH-60x40 trays total*

(**) *It can work more than 8 BH-60x40 trays total*

Modular NXE

eléctrico / electric

Características técnicas / Technical characteristics



TIPO / TYPE	Kw	Kcal/h	Fases Phases	V	A	Hz	Volumen / Volume dm ³
MODULO NXE-20 DECK NXE-20	9,4	8.100	3N~	230/ 400	25,9 / 14,9	50/60	234
MODULO NXE-20 +V DECK NXE-20 +V	10,8	8.100	3N~	230/400	29,4 / 16,9	50/60	234
MODULO NXEP-20 +V DECK NXEP-20 +V	10,8	8.100	3N~	230/ 400	29,4 / 16,9	50/60	234
MODULO NXE-30 DECK NXE-30	12,3	10.600	3N~	400	18,6	50/60	390
MODULO NXE-30 +V DECK NXE-30 +V	13,7	10.600	3N~	400	20,6	50/60	390
ESTUFA NXE+H PROOFER NXE+H	2,2	1800	1N~	230	10	50 / 60	3.542

Dimensiones / Dimensions

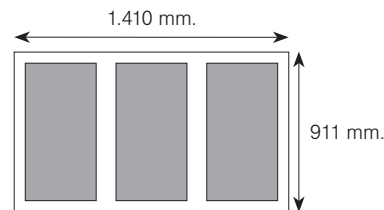
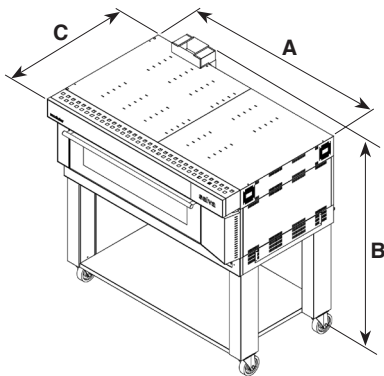

66 x 46, 75 x45

1,28 m²

Módulo Pastelero

Downward & outward opening module

NXE / NXEP	A mm	B mm	C mm	Peso / Weight Kg	Capacidad / Nº Trays
MODULO NXE-20 DECK NXE-20	1.912	315	1.316	229	3 (76 X 46)
MODULO NXE-20 CON VAPOR DECK NXE-20 +V	1.912	315	1.316 (*)	284	3 (76 X 46)
MODULO VAPOR NXEP-20 DECK NXEP-20 +V	1.912	315	1.364 (*)	293	3 (76 X 46)
MODULO NXE-30 DECK NXE-30	1.912	415	1.316	276	3 (76 X 46)
MODULO NXE-30 VAPOR DECK NXE-30 +V	1.912	415	1.316	323	3 (76 X 46)
ESTUFA NXE+H PROOFER NXE+H	1.912	704	1.167	150	3 (76 X 46) X 5 Alturas / Levels
BASE NXE BASE NXE	1.912	150	1.167	83	-
ENCIMERA NXE/NXEP TOP NXE/NXEP	1.912	165	1.331	57	-

(*) El fondo se debe aumentar en 23 mm. debido a los tubos de desagüe.

(*) The depth should be increase in 23 millimetres for the pipes of outlet

Modular NXE

eléctrico / *electric*

Accesorios / *Accessories*

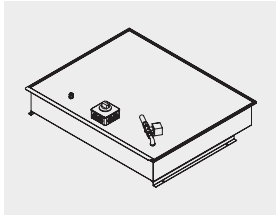

CONDENSADOR DE VAHOS / <i>AUTOMATIC CONDENSER</i>	
Código / <i>Code</i>	Descripción / <i>Description</i>
1124405100	CONDENSADOR VAHOS CV-E/13 (*) <i>AUTOMATIC CONDENSER CV-E/13 (*)</i>
1144405100	CONDENSADOR VAHOS CV-NXD/13 (**) <i>AUTOMATIC CONDENSER CV-NXD/13 (**)</i>

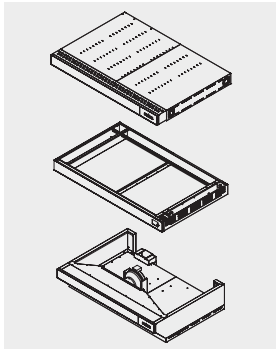

BASE/ENCIMERA / <i>BASE/TOP</i>	
Código / <i>Code</i>	Descripción / <i>Description</i>
1138296900	BASE/ENCIMERA NXEP/13 <i>BASE/TOP NXEP+13</i>
1138286900	BASE/ENCIMERA NXEP+V/13 <i>BASE/TOP NXEP+V/13</i>
1138286912	BASE/ENCIMERA NXEP+V/13 CON EXTRACTOR <i>BASE/TOP NXEP+V/13 EXTRACTOR</i>
1138286920	BASE/ENCIMERA NXEP/13 C/CVA <i>BASE/TOP NXEP/13 C/CVA</i>

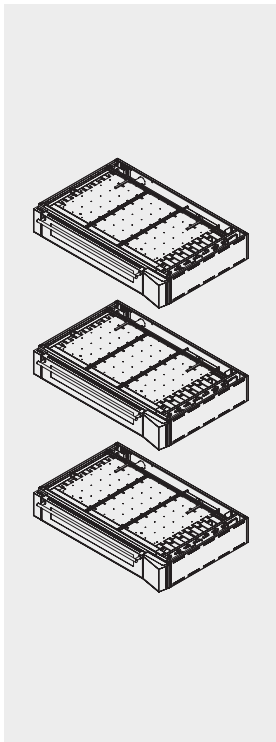

MODULO / <i>DECK</i>	
Código / <i>Code</i>	Descripción / <i>Description</i>
1138191900	MODULO NXE-20/13 ADVANCE Puerta Pastelera <i>DECK NXE-20/13 ADVANCE Patisserie Door</i>
1128691900	MODULO NXE-20/21 STC Puerta Pastelera <i>DECK NXE-20/21 STC Patisserie Door</i>
1138201900	MODULO NXE-20/13 VAPOR ADVANCE Puerta Pastelera <i>DECK NXE-20/13 +V ADVANCE Patisserie Door</i>
1128701900	MODULO NXE-20/21 VAPOR STC Puerta Pastelera <i>DECK NXE-20/21 +V STC Patisserie Door</i>
1138291900	MODULO NXEP-20/13 VAPOR ADVANCE Puerta Panadera <i>DECK NXEP-20/13 +V ADVANCE Baker's Door</i>
1128791900	MODULO NXEP-20/21 VAPOR STC Puerta Panadera <i>DECK NXEP-20/21 +V STC Baker's Door</i>
1138351900	MODULO NXE-30/13 ADVANCE 400V <i>DECK NXE-30/13 ADVANCE 400V</i>
1128851900	MODULO NXE-30/21 400V STC <i>DECK NXE-30/21 400V STC</i>
1138361900	MODULO NXE-30/13 VAPOR ADVANCE 400V <i>DECK NXE-30/13 +V ADVANCE 400V</i>
1128861900	MODULO NXE-30/21 VAPOR 400V STC <i>DECK NXE-30/21 +V 400V STC</i>

El horno incluye: Manopla Cogedor E

The oven includes: Heat resistant glove. Tray removing hook E

(*) Puede trabajar hasta 6 bandejas BH - 60x40 total

(**) Puede trabajar más de 8 bandejas BH - 60x40 total

() It can work til 6 BH-60x40 trays total*

*(**) It can work more than 8 BH-60x40 trays total*

Modular NXE

eléctrico / *electric*

Accesorios / *Accessories*

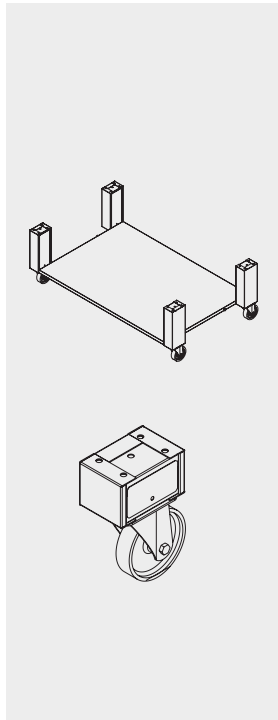

SOPORTE / <i>TRAY SUPPORT</i>	
Código / <i>Code</i>	Descripción / <i>Description</i>
1138198003	SOPORTE NXE-350/13 (Altura Patas 350 mm+ Ruedas 200 mm) <i>TRAY SUPPORT NXE-350/13 (Height of legs 350 mm+ Castors 200 mm)</i> Hasta 3 módulos / <i>Up to 3 decks</i>
1138198007	SOPORTE NXE-435/13 (Altura Patas 435 mm+ Ruedas 200 mm) <i>TRAY SUPPORT NXE-435/13 (Height of legs 435 mm + Castors 200 mm)</i> Hasta 3 módulos / <i>Up to 3 decks</i>
1138198006	SOPORTE NXE-530/13 (Altura Patas 530 mm+ Ruedas 200 mm) <i>TRAY SUPPORT NXE-530/13 (Height of legs 530 mm + Castors 200 mm)</i> Hasta 2 módulos / <i>Up to 2 decks</i>
1138198008	SOPORTE NXE-630/13 (Altura Patas 630 mm+ Ruedas 200 mm) <i>TRAY SUPPORT NXE-630/13 (Height of legs 630 mm + Castors 200 mm)</i> Hasta 2 módulos / <i>Up to 2 decks</i>
1138198005	SOPORTE NXE-730/13 (Altura Patas 730 mm+ Ruedas 200 mm) <i>TRAY SUPPORT NXE-730/13 (Height of legs 730 mm + Castors 200 mm)</i> Hasta 2 módulos / <i>Up to 2 decks</i>
1124491000	SOPORTE MODULAR 100 (Patas 100 mm+ Ruedas 200 mm) <i>TRAY SUPPORT 100 (Legs 100 mm + Castors 200 mm)</i> Hasta 4 módulos / <i>Up to 4 decks</i>
1124492000	SOPORTE MODULAR 200 (Patas 200 mm+ Ruedas 200 mm) <i>TRAY SUPPORT 200 (Legs 200 mm + Castors 200 mm)</i> Hasta 4 módulos / <i>Up to 4 decks</i>

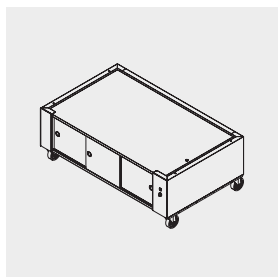

ESTUFA / <i>PROOFER</i>	
Código / <i>Code</i>	Descripción / <i>Description</i>
1138197900	ESTUFA NXE+H/13 C/RUEDAS <i>PROOFER NXE+H/13 C/RUEDAS</i>

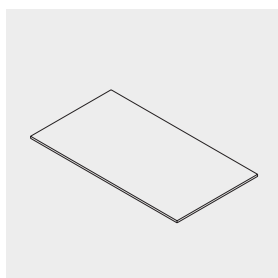

SOLERAS / <i>COMPOSITE STONE SOLE</i>	
Código / <i>Code</i>	Descripción / <i>Description</i>
1138193008	SOLERA CEMENTADA NXE/13 JUEGO <i>COMPOSITE STONE SOLE NXE/13</i>

El horno incluye: Manopla Cogedor E

The oven includes: Heat resistant glove. Tray removing hook E

(*) Puede trabajar hasta 6 bandejas BH - 60x40 total

(**) Puede trabajar más de 8 bandejas BH - 60x40 total

(*) *It can work til 6 BH-60x40 trays total*

(**) *It can work more than 8 BH-60x40 trays total*

Modular NXD

eléctrico / electric

Características técnicas / Technical characteristics



TIPO / TYPE	Kw	Kcal/h	Fases Phases	V	A	Hz	Volumen / Volume dm ³
MODULO NXD-20 +V DECK NXD-20 +V	19,8	14.900	3N~	400	30	50/60	500
MODULO NXDP-20 +V DECK NXDP-20 +V	19,8	14.900	3N~	400	30	50/60	500

Dimensiones / Dimensions

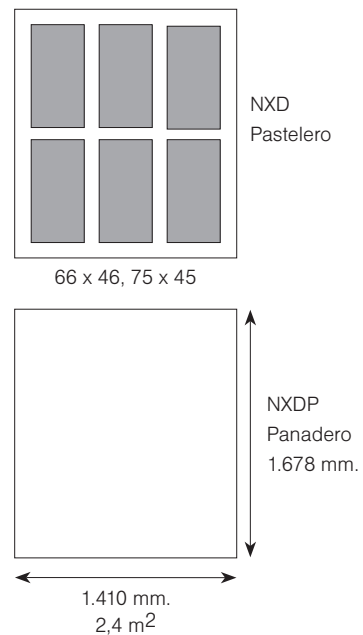
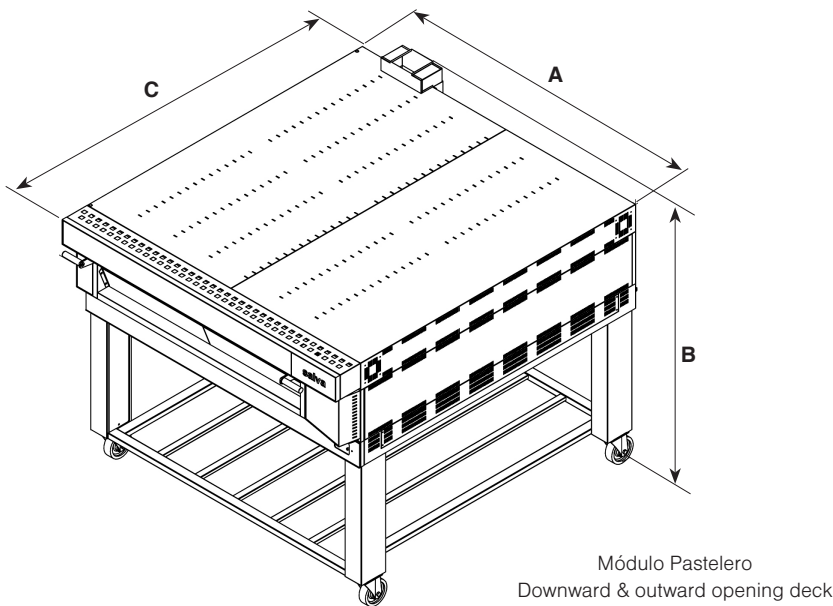

NXD / NXDP	A mm	B mm	C mm	Peso / Weight Kg	Capacidad / N° Trays
MODULO NXD-20 CON VAPOR DECK NXD-20 +V	1.912	315	2.083 (*)	431	6 (76 X 46)
MODULO NXDP-20 VAPOR DECK NXDP-20 +V	1.912	315	2.131 (*)	441	6 (76 X 46)
BASE NXD BASE NXD	1.912	150	1.934	122	-
ENCIMERA NXDP TOP NXDP	1.912	165	2.098	86	-

(*) El fondo se debe aumentar en 23 mm. debido a los tubos de desagüe.

(*) The depth should be increase in 23 millimetres for the pipes of outlet

Modular NXD

eléctrico / electric

Accesorios / Accessories

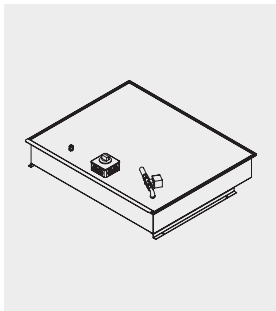

CONDENSADOR DE VAHOS / AUTOMATIC CONDENSER	
Código / Code	Descripción / Description
1124405100	CONDENSADOR VAHOS CV-E/13 (*) AUTOMATIC CONDENSER CV-E/13 (*)
1144405100	CONDENSADOR VAHOS CV-NXD/13 (**) AUTOMATIC CONDENSER CV-NXD/13 (**)

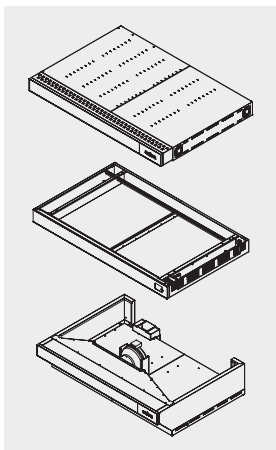

BASE/ENCIMERA / BASE/TOP	
Código / Code	Descripción / Description
1138326901	BASE/ENCIMERA NXDP/13 BASE/TOP NXDP/13
1138326900	BASE/ENCIMERA NXDP+V/13 BASE/TOP NXDP+V/13
1138326912	BASE/ENCIMERA NXDP+V/13 CON EXTRACTOR BASE/TOP NXDP+V/13 EXTRACTOR
1138326920	BASE/ENCIMERA NXDP/13 C/CVA BASE/TOP NXDP/13 C/CVA

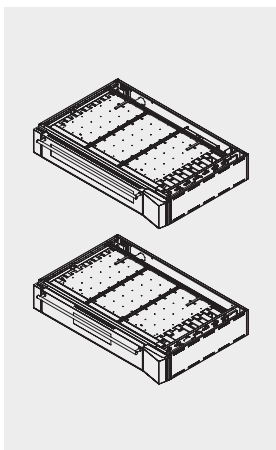

MODULO / DECK	
Código / Code	Descripción / Description
1138261900	MODULO NXD-20/13 VAPOR 400V ADVANCE Puerta Pastelera DECK NXD-20/13 +V 400V ADVANCE Patisserie Door
1128761900	MODULO NXD-20/21 VAPOR 400V STC Puerta Pastelera DECK NXD-20/21 +V 400V STC Patisserie Door
1138321900	MODULO NXDP-20/13 VAPOR 400V ADVANCE Puerta Panadera DECK NXDP-20/13 +V 400V ADVANCE Baker's Door
1128821900	MODULO NXDP-20/21 VAPOR 400V STC Puerta Panadera DECK NXDP-20/21 +V 400V STC Baker's Door

El horno incluye: Manopla Cogedor E
The oven includes: Heat resistant glove. Tray removing hook E

(*) Puede trabajar hasta 6 bandejas BH - 60x40 total
(**) Puede trabajar más de 8 bandejas BH - 60x40 total
(* It can work til 6 BH-60x40 trays total
(** It can work more than 8 BH-60x40 trays total

Modular NXD

eléctrico / *electric*

Accesorios / *Accessories*

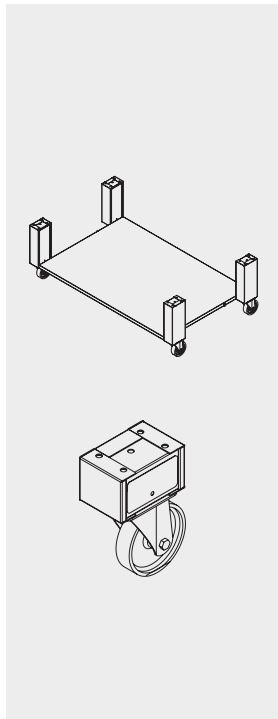

SOPORTE / <i>TRAY SUPPORT</i>	
Código / <i>Code</i>	Descripción / <i>Description</i>
1138268003	SOPORTE NXD-350/13 (Altura Patas 350 mm+ Ruedas 200 mm) <i>TRAY SUPPORT NXD-350/13 (Height of legs 350 mm+ Castors 200 mm)</i> Hasta 3 módulos / <i>Up to 3 decks</i>
1138268004	SOPORTE NXD-435/13 (Altura Patas 435 mm+ Ruedas 200 mm) <i>TRAY SUPPORT NXD-435/13 (Height of legs 435 mm + Castors 200 mm)</i> Hasta 3 módulos / <i>Up to 3 decks</i>
1138268005	SOPORTE NXD-530/13 (Altura Patas 530mm+ Ruedas 200 mm) <i>TRAY SUPPORT NXD-530/13 (Height of legs 530mm + Castors 200 mm)</i> Hasta 2 módulos / <i>Up to 2 decks</i>
1138268006	SOPORTE NXD-630/13 (Altura Patas 630 mm+ Ruedas 200 mm) <i>TRAY SUPPORT NXD-630/13 (Height of legs 630 mm + Castors 200 mm)</i> Hasta 2 módulos / <i>Up to 2 decks</i>
1138268007	SOPORTE NXD-730/13 (Altura Patas 730 mm+ Ruedas 200 mm) <i>TRAY SUPPORT NXD-730/13 (Height of legs 730 mm + Castors 200 mm)</i> Hasta 2 módulos / <i>Up to 2 decks</i>
1124491000	SOPORTE MODULAR 100 (Patas 100 mm+ Ruedas 200 mm) <i>TRAY SUPPORT 100 (Legs 100 mm + Castors 200 mm)</i> Hasta 4 módulos / <i>Up to 4 decks</i>
1124492000	SOPORTE MODULAR 200 (Patas 200 mm+ Ruedas 200 mm) <i>TRAY SUPPORT 200 (Legs 200 mm + Castors 200 mm)</i> Hasta 4 módulos / <i>Up to 4 decks</i>

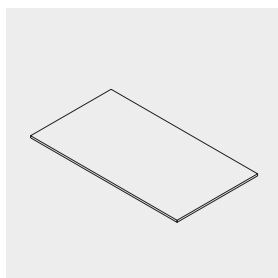

SOLERAS / <i>COMPOSITE STONE SOLE</i>	
Código / <i>Code</i>	Descripción / <i>Description</i>
1138263009	SOLERA CEMENTADA NXD/13 JUEGO <i>COMPOSITE STONE SOLE NXD/13</i>

El horno incluye: Manopla Cogedor E
The oven includes: Heat resistant glove. Tray removing hook E

(*) Puede trabajar hasta 6 bandejas BH - 60x40 total
(**) Puede trabajar más de 8 bandejas BH - 60x40 total
(* *It can work til 6 BH-60x40 trays total*
(** *It can work more than 8 BH-60x40 trays total*

Modular LXP

eléctrico / electric

Características técnicas / Technical characteristics

TIPO / TYPE	Kw	Kcal/h	Fases Phases	V	A	Hz	Volumen / Volume dm ³
MODULO LXP-20 +V DECK LXP-20 +V	12,8	9.900	3N~	400	18,9	50 / 60	304

Dimensiones / Dimensions

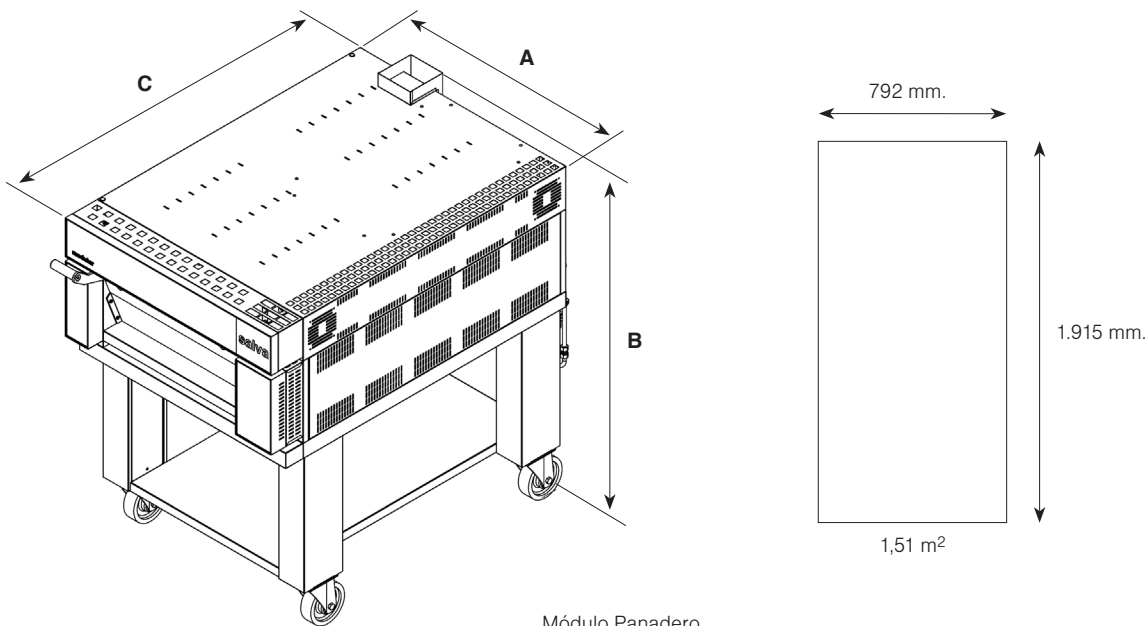

Módulo Panadero
Inward & outward opening deck

LXP	A mm	B mm	C mm	Peso / Weight Kg	Capacidad / Nº Trays
MODULO LXP-20 VAPOR DECK LXP-20 +V	1.292	315	2.429 (*)	260	4 (76 X 46)
BASE LXP BASE LXP	1.292	150	2.154	70	-
ENCIMERA LXP TOP LXP	1.292	165	2.378	70	-

(*) El fondo se debe aumentar en 23 mm. debido a los tubos de desagüe.
(*) The depth should be increase in 23 millimetres for the pipes of outlet

Modular LXP

eléctrico / *electric*

Accesorios / *Accessories*

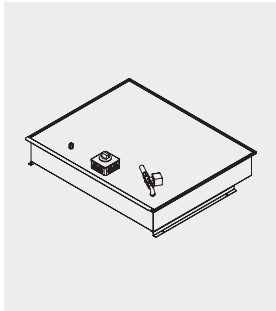

CONDENSADOR DE VAHOS / <i>AUTOMATIC CONDENSER</i>	
Código / <i>Code</i>	Descripción / <i>Description</i>
1124405100	CONDENSADOR VAHOS CV-E/13 (*) <i>AUTOMATIC CONDENSER CV-E/13 (*)</i>
1144405100	CONDENSADOR VAHOS CV-NXD/13 (**) <i>AUTOMATIC CONDENSER CV-NXD/13 (**)</i>

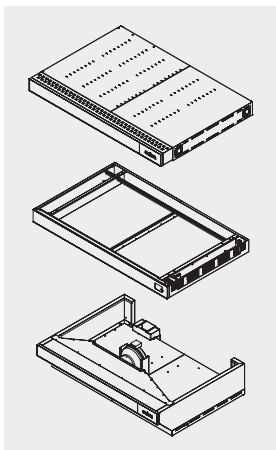

BASE/ENCIMERA / <i>BASE/TOP</i>	
Código / <i>Code</i>	Descripción / <i>Description</i>
1138386900	BASE/ENCIMERA LXP+V/13 <i>BASE/TOP LXP+V/13</i>
1138386921	BASE/ENCIMERA LXP+V/13 CON EXTRACTOR <i>BASE/TOP LXP+V/13 EXTRACTOR</i>

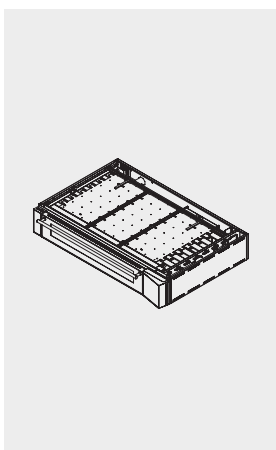

MODULO / <i>DECK</i>	
Código / <i>Code</i>	Descripción / <i>Description</i>
1138381900	MODULO LXP-20/13 VAPOR ADVANCE Puerta Panadera <i>DECK LXP-20/13 +V ADVANCE Baker's Door</i>
1128881900	MODULO LXP-20/21 VAPOR 400V STC Puerta Panadera <i>DECK LXP-20/21 +V 400V STC Baker's Door</i>

El horno incluye: Manopla Cogedor E
The oven includes: Heat resistant glove. Tray removing hook E

(*) Puede trabajar hasta 6 bandejas BH - 60x40 total
 (**) Puede trabajar más de 8 bandejas BH - 60x40 total
 (*) *It can work til 6 BH-60x40 trays total*
 (**) *It can work more than 8 BH-60x40 trays total*

Modular LXP

eléctrico / *electric*

Accesorios / *Accessories*

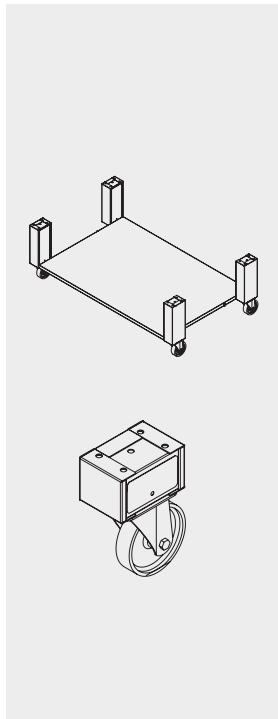

SOPORTE / <i>TRAY SUPPORT</i>	
Código / <i>Code</i>	Descripción / <i>Description</i>
1138388003	SOPORTE LXP-350/13 (Altura Patas 350 mm+ Ruedas 200 mm) <i>TRAY SUPPORT LXP-350/13 (Height of legs 350 mm+ Castors 200 mm)</i> Hasta 3 módulos / <i>Up to 3 decks</i>
1138388004	SOPORTE LXP-435/13 (Altura Patas 435 mm+ Ruedas 200 mm) <i>TRAY SUPPORT LXP-435/13 (Height of legs 435 mm + Castors 200 mm)</i> Hasta 3 módulos / <i>Up to 3 decks</i>
1138388005	SOPORTE LXP-530/13 (Altura Patas 530 mm+ Ruedas 200 mm) <i>TRAY SUPPORT LXP-530/13 (Height of legs 530 mm + Castors 200 mm)</i> Hasta 2 módulos / <i>Up to 2 decks</i>
1138388006	SOPORTE LXP-630/13 (Altura Patas 630 mm+ Ruedas 200 mm) <i>TRAY SUPPORT LXP-630/13 (Height of legs 630 mm + Castors 200 mm)</i> Hasta 2 módulos / <i>Up to 2 decks</i>
1138388007	SOPORTE LXP-730/13 (Altura Patas 730 mm+ Ruedas 200 mm) <i>TRAY SUPPORT LXP-730/13 (Height of legs 730 mm + Castors 200 mm)</i> Hasta 2 módulos / <i>Up to 2 decks</i>
1124491000	SOPORTE MODULAR 100 (Patas 100 mm+ Ruedas 200 mm) <i>TRAY SUPPORT 100 (Legs 100 mm + Castors 200 mm)</i> Hasta 4 módulos / <i>Up to 4 decks</i>
1124492000	SOPORTE MODULAR 200 (Patas 200 mm+ Ruedas 200 mm) <i>TRAY SUPPORT 200 (Legs 200 mm + Castors 200 mm)</i> Hasta 4 módulos / <i>Up to 4 decks</i>

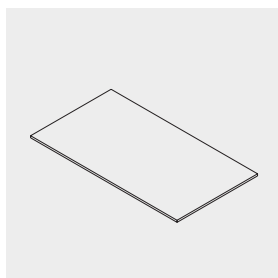

SOLERAS / <i>COMPOSITE STONE SOLE</i>	
Código / <i>Code</i>	Descripción / <i>Description</i>
1138383007	SOLERA CEMENTADA LXP/13 JUEGO <i>COMPOSITE STONE SOLE LXP/13</i>

El horno incluye: Manopla Cogedor E
The oven includes: Heat resistant glove. Tray removing hook E

(*) Puede trabajar hasta 6 bandejas BH - 60x40 total
(**) Puede trabajar más de 8 bandejas BH - 60x40 total
(* *It can work til 6 BH-60x40 trays total*
(** *It can work more than 8 BH-60x40 trays total*

Modular

cargador / setter



CARGADOR ELEVADOR INTEGRADO / INTEGRATED SETTER-ELEVATOR	
Código / Code	Descripción / Description
5127350000	CARGADOR ELEVADOR INTEGRADO NXDP/13 <i>INTEGRATED SETTER-ELEVATOR NXDP/13</i>
5127380000	CARGADOR ELEVADOR INTEGRADO LXP/13 <i>INTEGRATED SETTER-ELEVATOR LXP/13</i>
5127390000	CARGADOR ELEVADOR INTEGRADO EMT/16 <i>INTEGRATED SETTER-ELEVATOR EMT/16</i>
5127360000	CARGADOR ELEVADOR INTEGRADO NXEP/13 <i>INTEGRATED SETTER-ELEVATOR NXEP/13</i>
5127370000	CARGADOR ELEVADOR INTEGRADO NXMP/13 <i>INTEGRATED SETTER-ELEVATOR NXMP/13</i>
	CARGADOR ELEVADOR INTEGRADO EDP/21 <i>INTEGRATED SETTER-ELEVATOR EDP/21</i>

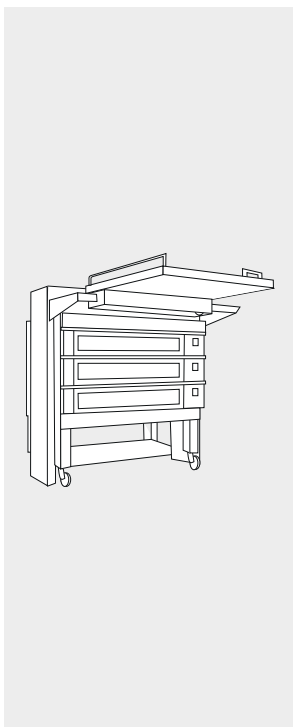

CARGADOR ELEVADOR INTEGRADO CARGA COMPLETA INTEGRATED LIFTER-SETTER WITH FULL LOADING	
Código / Code	Descripción / Description
5127391000	CARGADOR ELEVADOR INTEGRADO NXDP/13 <i>INTEGRATED SETTER-ELEVATOR NXDP/13</i>
5127392000	CARGADOR ELEVADOR INTEGRADO NXEP/13 <i>INTEGRATED SETTER-ELEVATOR NXEP/13</i>

Altura mínima de trabajo 630 mm
Minimum working High 560 mm

Modular

cargador / setter



CARGADOR MANUAL (Sin Elevador) / MANUAL SETTER (Without Elevator)	
Código / Code	Descripción / Description
5127010000	CARGADOR MANUAL CM-LXP MANUAL SETTER CM-LXP
5127310000	CARGADOR MANUAL CM-NXDP MANUAL SETTER CM-NXDP
5127320000	CARGADOR MANUAL CM-NXEP MANUAL SETTER CM-NXEP
5127311000	CARGADOR MANUAL CM-NXMP MANUAL SETTER CM-NXMP
5127312000	CARGADOR MANUAL CM-EMT MANUAL SETTER CM-EMT
5127313000	CARGADOR MANUAL CM-EDP MANUAL SETTER CM-EDP

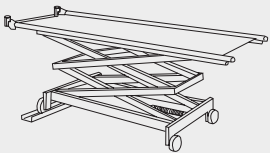

CARGADOR-ELEVADOR DE TIJERA / DOUBLE SCISSOR TYPE SETTER-ELEVATOR	
Código / Code	Descripción / Description
5127190000	CARGADOR-ELEVADOR TIJERA LXP IZDA (Manual) DOUBLE SCISSOR TYPE SETTER-ELEVATOR LXP LEFT (Manual)
5127190000	CARGADOR-ELEVADOR TIJERA LXP DCHA (Manual) DOUBLE SCISSOR TYPE SETTER-ELEVATOR LXP RIGHT (Manual)
5127270000	CARGADOR-ELEVADOR TIJERA NXDP IZDA (Manual) DOUBLE SCISSOR TYPE SETTER-ELEVATOR NXDP LEFT (Manual)
5127270000	CARGADOR-ELEVADOR TIJERA NXDP DCHA (Manual) DOUBLE SCISSOR TYPE SETTER-ELEVATOR NXDP RIGHT (Manual)
5127280000	CARGADOR- ELEVADOR TIJERA NXEP IZDA (Manual) DOUBLE SCISSOR TYPE SETTER-ELEVATOR NXEP LEFT (Manual)
5127280000	CARGADOR- ELEVADOR TIJERA NXEP DCHA (Manual) DOUBLE SCISSOR TYPE SETTER-ELEVATOR NXEP RIGHT (Manual)
5127281000	CARGADOR- ELEVADOR TIJERA NXMP/13 (Manual) DOUBLE SCISSOR TYPE SETTER-ELEVATOR NXMP/13 (Manual)

Altura mínima de trabajo 630 mm
Minimum working High 560 mm

Modular

cargador / setter

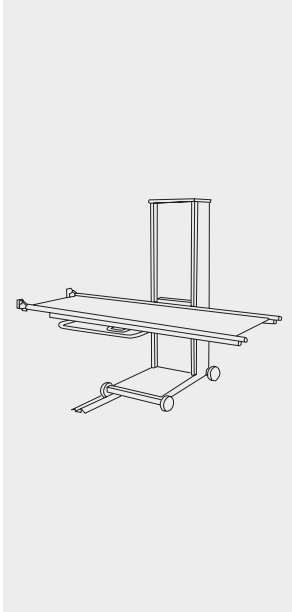

CARGADOR-ELEVADOR DE COLUMNA / COLUMN SETTER-ELEVATOR	
Código / Code	Descripción / Description
5127150000	CARGADOR-ELEVADOR COLUMNA LXP IZDA (Manual) <i>COLUMN SETTER-ELEVATOR LXP LEFT (Manual)</i>
5127150000	CARGADOR-ELEVADOR COLUMNA LXP DCHA (Manual) <i>COLUMN SETTER-ELEVATOR LXP RIGHT (Manual)</i>
5127250000	CARGADOR-ELEVADOR COLUMNA NXDP IZDA (Manual) <i>COLUMN SETTER-ELEVATOR NXDP LEFT (Manual)</i>
5127250000	CARGADOR-ELEVADOR COLUMNA NXDP DCHA (Manual) <i>COLUMN SETTER-ELEVATOR NXDP RIGHT (Manual)</i>
5127260000	CARGADOR- ELEVADOR COLUMNA NXEP IZDA (Manual) <i>COLUMN SETTER-ELEVATOR NXEP LEFT (Manual)</i>
5127260000	CARGADOR- ELEVADOR COLUMNA NXEP DCHA (Manual) <i>COLUMN SETTER-ELEVATOR NXEP RIGHT (Manual)</i>
5127261000	CARGADOR- ELEVADOR COLUMNA NXMP/13 (Manual) <i>COLUMN SETTER-ELEVATOR NXMP/13 (Manual)</i>

Altura mínima de trabajo 630 mm
Minimum working High 560 mm

MESA DE CARGA PARA APOYO TABLEROS / TABLE FOR SOPPORTING BOARDS	
Código / Code	Descripción / Description
5120010000	MESA LXP <i>TABLE LXP</i>
5120030000	MESA NXDP <i>TABLE NXDP</i>
5120040000	MESA NXEP <i>TABLE NXEP</i>

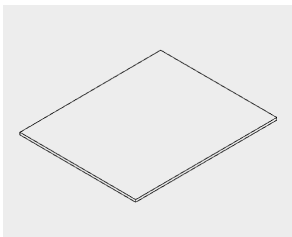

TABLEROS / WOODEN BOARDS	
Código / Code	Descripción / Description
5126201190	TABLERO LXP <i>WOODEN BOARD LXP</i>
5126201140	TABLERO NXEP <i>WOODEN BOARD NXEP</i>

(*) Para alturas diferentes consultar.
() For different height please consult us.*

Relación de símbolos

Symbol relationship



Hotel
Hotel



Supermercado
Supermarket



Estación de servicio
Gas station



Cafetería
Coffee shop

Hornos / Ovens



Eléctrico
Electric



Gas o gas oil
Gas or diesel



Gas, gasoil o eléctrico
Gas, diesel or electric



Horno de convección
Convection oven



Horno de radiación
Radiant heat oven

Características técnicas / *Technical characteristics*



Ampliable modular
Can grow modular



Espacio reducido
Small foot print



Agua fría
Cold water



Bajo consumo
Low energy consumption



Fermentación directa
Direct proofing



Limpieza
Easy to clean



Calidad de vapor
Steam quality



Frío-calor
Cold-heat



Movilidad
Mobility



Calidad
Quality



Gran aislamiento
Well insulated



Opción conectividad
Connectivity option



Carro rotativo
Rack rotating



Gran producción
High production



Pan y bollería
Bread and danish pastries



Conexion rápida
Plug and play



Horno de convección
Convection oven



Precisión
Precision



Control de humedad
Humidity control



Tecnología Touch
Touch technology



Rápida respuesta
Quick response



Control de temperatura
Temperature control



Control de temperatura
Temperature control



Resistente
Heavy duty

salva

SALVA INDUSTRIAL S.L.U.
GI-636, Km 6 - Pol. 107
20100 Lezo (Guipuzcoa)
España